

The Universal Cube

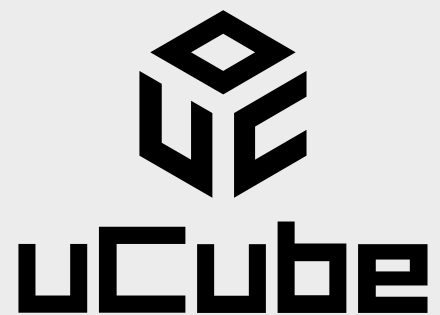

www.ucube.swiss

AEREM[®]
TO FILTER & PROTECT

Produced by Aerem
www.aerem.com

Summary

1	The universal cube	4
2	Technologies	5
3	Why choose uCube?	6-7
4	Products	8-9
5	Installation	10-13

The Universal Cube

uCube was developed by AEREM, based on the inertia separation technology using the best of the existing and recyclable raw materials, namely cardboard and polyester. The mix of these materials gave the best loading capacity and filtration efficiency. Our universal cube was born in early 2019 and adapted to heavy paints. It is the highest loading capacity filter on the market.

Aerem Industrie group developed in 2023 the SPRAYMESH filter. This expanded paper type filter, together with our Andreae filters line and our UCUBE filters line, positions Aerem as the only over spray exhaust filter manufacturer in the world with a full range of filters meeting all paint types and all spray booth configurations.

This accumulated knowledge led us to develop (available mid-2024) a new version of our uCube integrating our new Spraymesh filter technology dedicated to fast drying paints.

All our research and development make our global uCube range an easy product to assemble and to install, reducing costs and optimizing transport and storage.



TECHNOLOGIES

HEAVY

Loader:

At first, the Loader will filter 74% of the paint.

Catcher:

Then, the Catcher will stop 24% of the extra paint thanks to its polyester filter.

Perfector:

And finally, the Perfector will trap the remaining particles to achieve a 99,8% filtration efficiency.

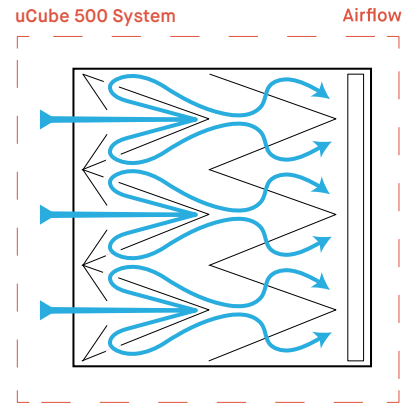
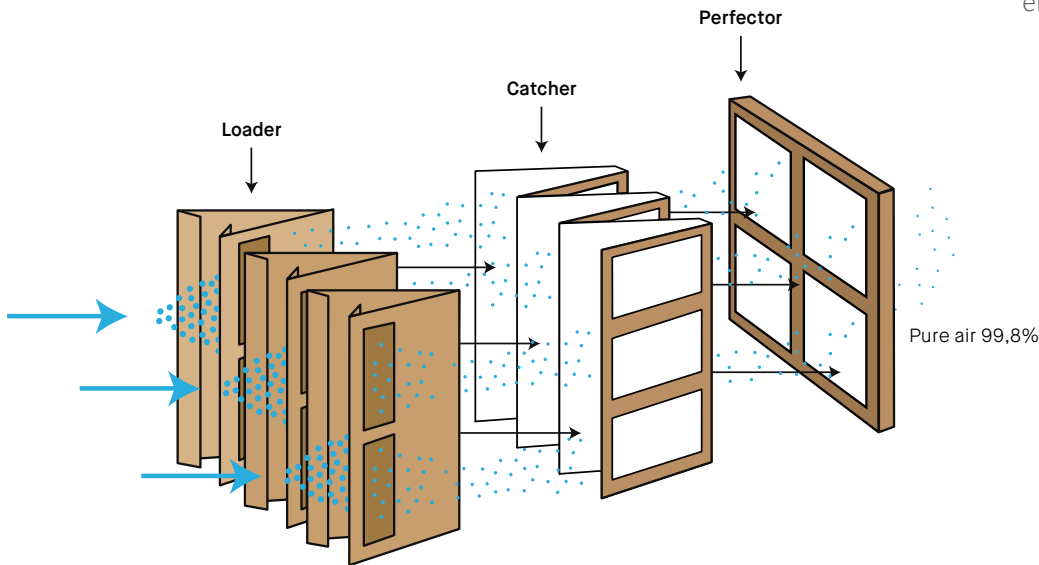

LIGHT

Collector:

Spraymesh CAPACITY paint collector ; 8 layers of woven paper mesh fixed on a strong cardboard structure to create deep deposit areas.

Perfector:

And finally, the Perfector will trap the remaining particles to achieve a 99,8% filtration efficiency. Available in 2 different grades of paint particles filtration.

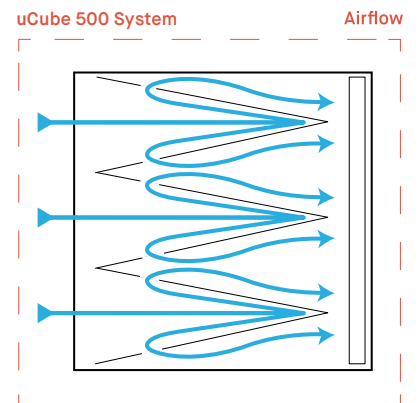
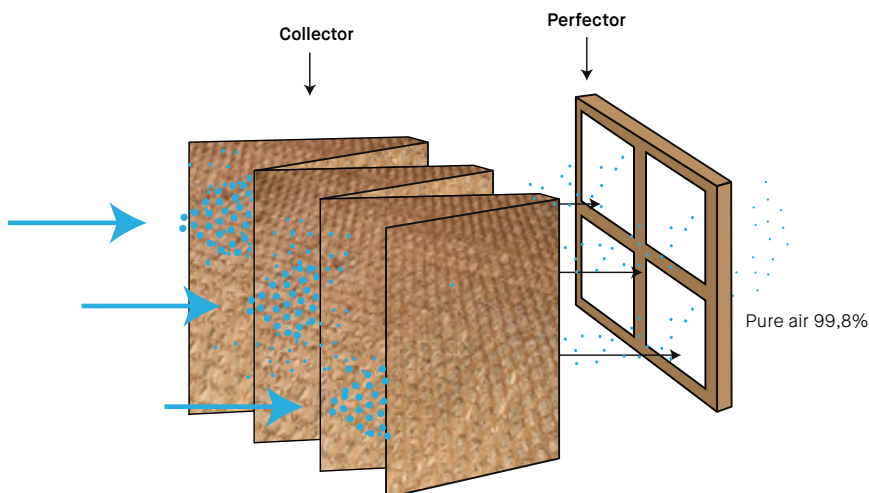

Why choose uCube ?

- ✓ Adapted to all paint types and applications
- ✓ Modular systems
- ✓ Cost efficient
- ✓ Up to 100 kg loading capacity/m²
– 55 lbs/cube*
- ✓ Efficiency up to 99.45 %
- ✓ Quick Installation
- ✓ Optimized transport costs

* depending on paint type



HEAVY

The uCube H range is dedicated to heavy, sticky paints which dry slowly like primers, adhesives, bake dry enamels, epoxies, frit, etc..



✓ Charge: Over 30kg

✓ Efficiency: 99,45%

LIGHT

The uCube L range is dedicated to fast dry light paints like air-dry enamels, clear coats, nitrocellulose, air-dry primers, etc..



✓ Capacity: up to 80 kg/m² –
45 lbs/cube

✓ Efficiency: up to 99%

HEAVY

300

Dimensions:

Length: 48,7 cm - 19 11/64 in

Height: 48,7 cm - 19 11/64 in

Width: 29,7 cm - 11 16/16 in

Recommended Air Velocity: 0.8 to 2 m/s
– 160 to 400 ft/min

Initial Pressure Drop: 20 Pa at 0.8 m/s to 90 Pa at 2 m/s
0.08" WC at 150 ft/min to 0.35" WC at 400 ft/min

Max Pressure Drop: 1000 Pa – 4" WC

500

Dimensions:

Length: 48,7 cm - 19 11/64 in

Height: 48,7 cm - 19 11/64 in

Width: 49,7 cm - 19 9/16 in

Recommended Air Velocity: 0.8 to 2 m/s
– 160 to 400 ft/min

Initial Pressure Drop: 35 Pa at 0.8 m/s to 130 Pa at 2 m/s
0.14" WC at 150 ft/min to 0.5" WC at 400 ft/min

Max Pressure Drop: 1000 Pa – 4" WC

300



Code: UC300H1

500



Code: UC500H1

LIGHT

Available in 3 different versions to improve find the best balance loading / efficiency according to paint type :

1. Collector
2. Collector + perfector with dedicated paint polyester
3. Collector + perfector with air filtration polyester
4. Collector + perfector with fiber glass

300

Dimensions:

Length: 48,7 cm - 19 11/64 in

Height: 48,7 cm - 19 11/64 in

Width: 29,7 cm - 11 16/16 in

Recommended Air Velocity: 0.3 to 1.5 m/s
– 160 to 400 ft/min

Initial Pressure Drop: 10 Pa at 0.8 m/s to 85 Pa at 2 m/s
0.04" WC at 150 ft/min to 0.35" WC at 400 ft/min

Max Pressure Drop: 1000 Pa – 4" WC

500

Dimensions:

Length: 48,7 cm - 19 11/64 in

Height: 48,7 cm - 19 11/64 in

Width: 49,7 cm - 19 9/16 in

Recommended Air Velocity: 0.3 to 1.5 m/s
– 100 to 300 ft/min

Initial Pressure Drop: 12 Pa at 0.8 m/s to 100 Pa at 2 m/s
0.105" WC at 150 ft/min to 0.4" WC at 400 ft/min

Max Pressure Drop: 1000 Pa – 4" WC

300



Codes:

1. Collector : UC300L800
2. Collector + perfector with dedicated paint polyester : UC300L801
3. Collector + perfector with air filtration polyester : UC300L802
4. Collector + perfector with fiber glass : UC300L803

500



Codes:

1. Collector : UC500L800
2. Collector + perfector with dedicated paint polyester : UC500L801
3. Collector + perfector with air filtration polyester : UC500L802
4. Collector + perfector with fiber glass : UC500L803

HEAVY - INSTALLATION GUIDE 300 & 500

Same box, multiple
versions adapted to
application types.

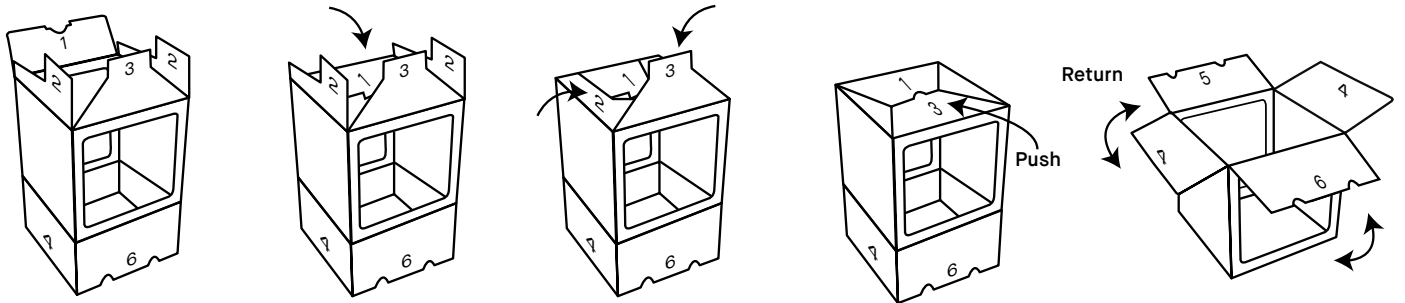

300

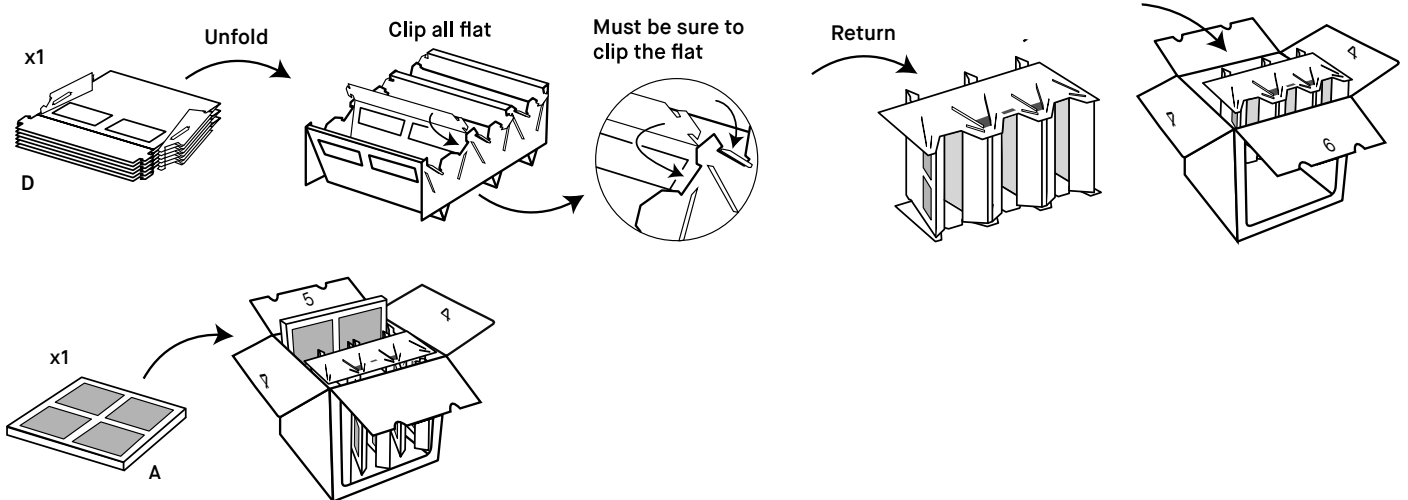

500

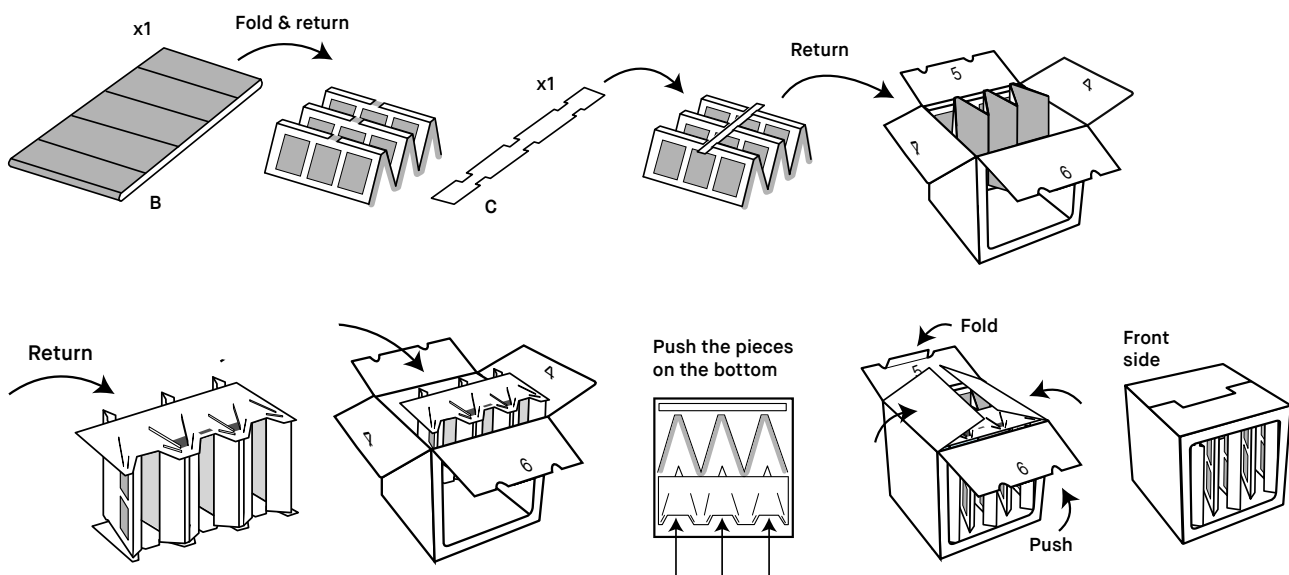

The set-up videos are available here:
www.ucube.swiss
Aerem Youtube Channel

LIGHT - INSTALLATION GUIDE 300 & 500

Perfector should be
installed according to
Ucube type

300 & 500

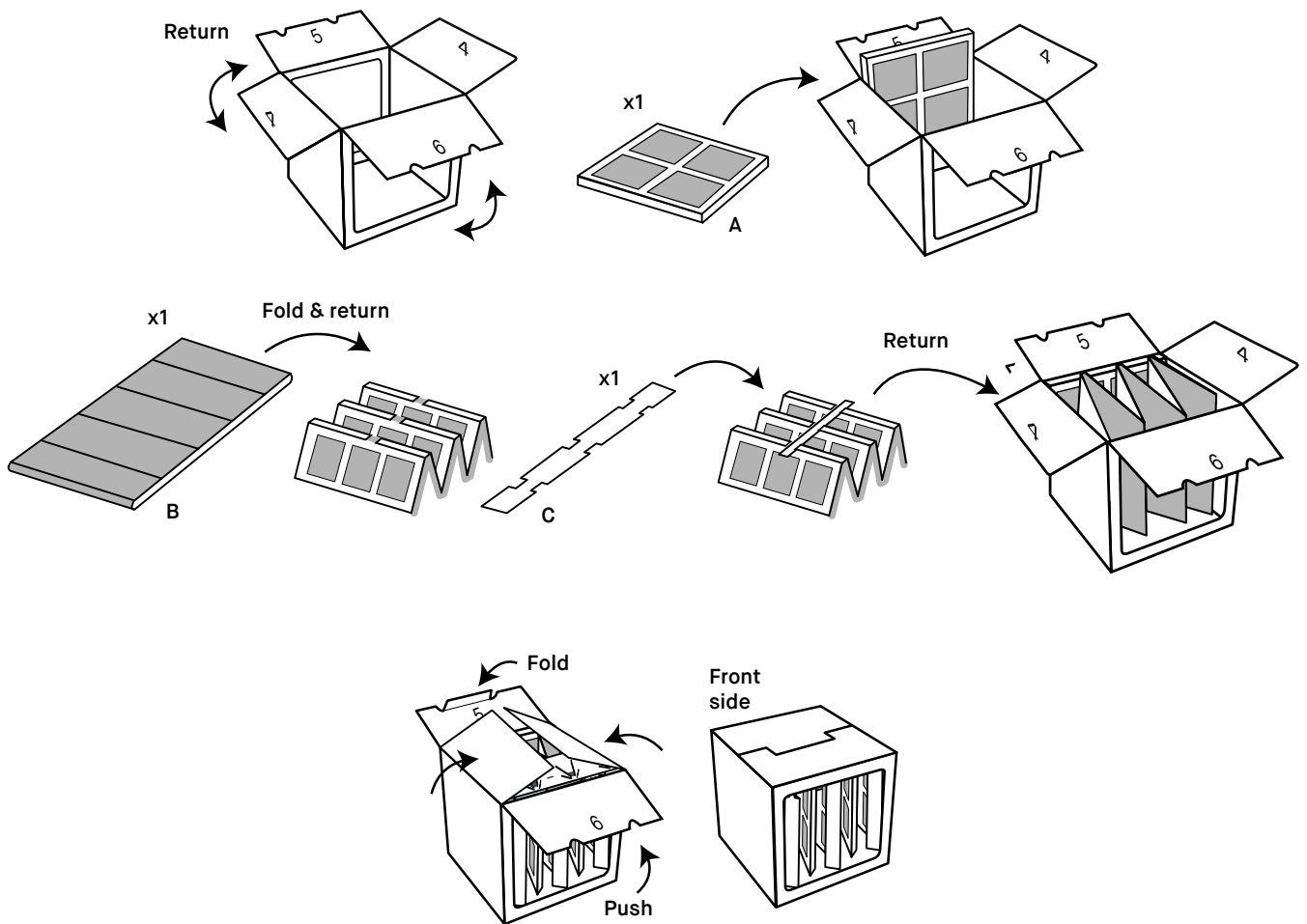

uCube Cabin Installation



Whatever Ucube you choose, installation mode is the same.



①

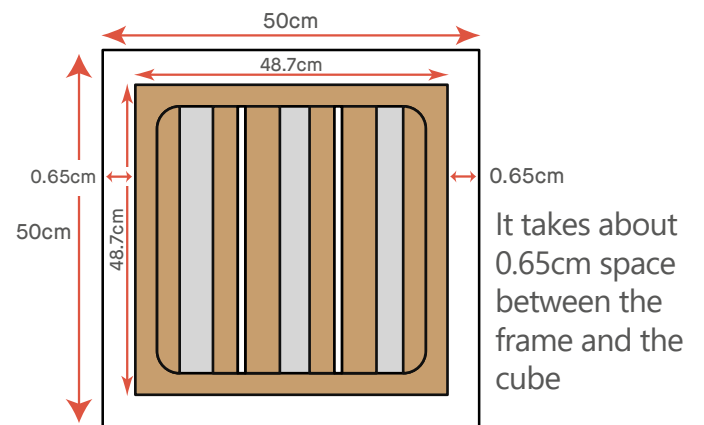
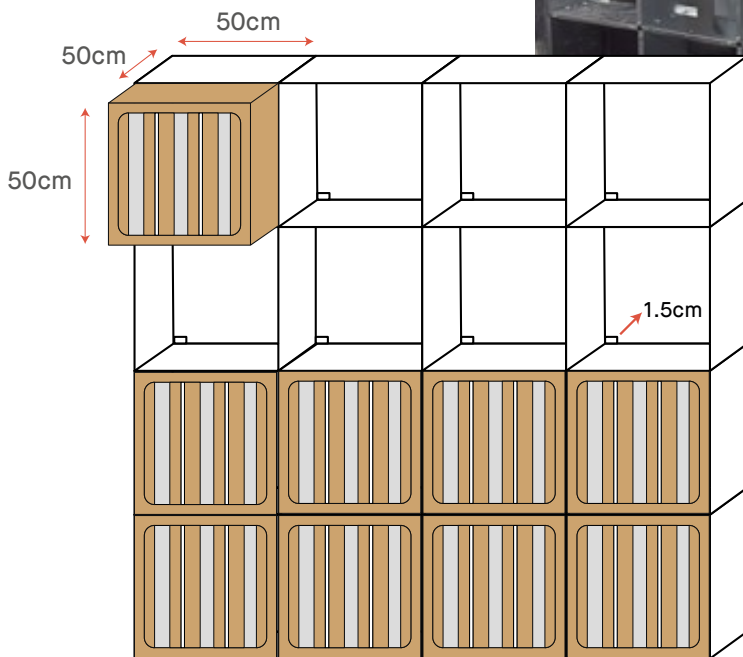

②

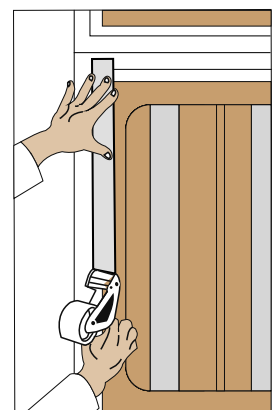

Apply tape all around the frame to maintain the cube.

We offer uCube 500 or uCube 300 depending on the space you have for the installation depth.

Spraying Room

A full filtration wall for all spray booths

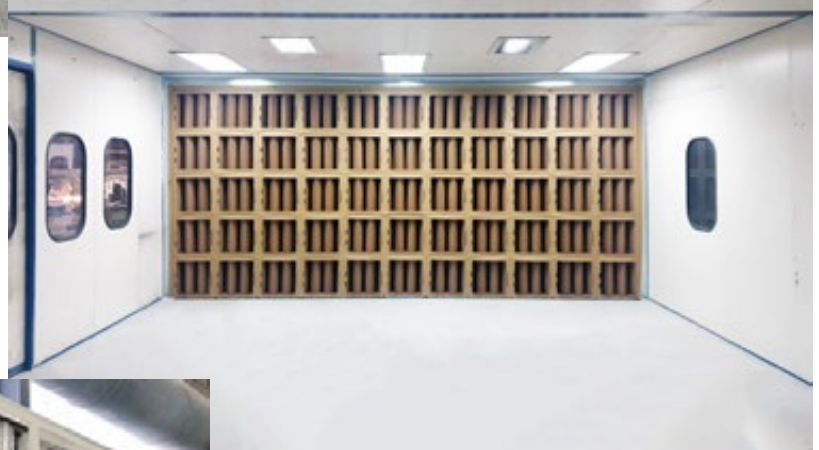
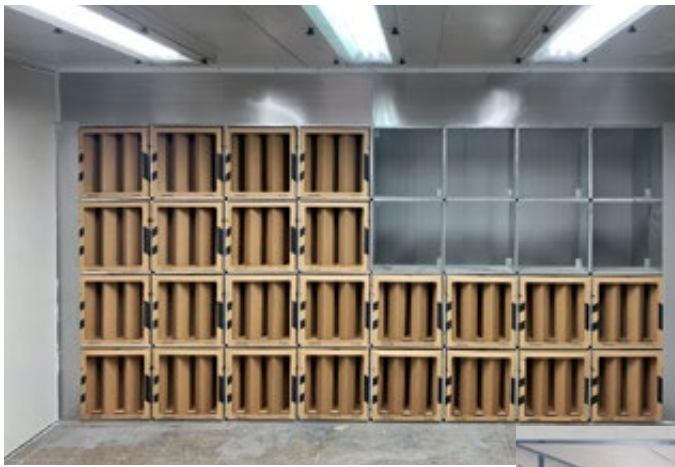

AEREM[®]

TO FILTER & PROTECT

OUR MISSION

Aerem focuses on its customers and partners needs in the finishing industry. Every relationship is a privileged partnership based on professionalism, dialog and trust. Delivering the best service with performant, environmentally friendly quality products easy to dispose of is our commitment since 1963.

Our mission is to develop, manufacture and supply high performant filtration and protection products for spray booths that aim to keep a clean and safe working environment while enhancing the spray booths productivity.

OUR VISION

Aerem's ambition is to affirm its position by becoming an international multi-brand company focused on the global finishing industry with a wide variety of renowned and innovative filtration and protection products.

OUR VALUES

Aerem is above all a work of men and women united around the world for the success of the Group. They all share the same values in a solidarity and caring climate.



ENVIRONMENT

Protecting the environment is the responsibility of everyone. Aerem uses recycled raw materials in all of its products. Our sharply tuned and performant production processes results in low waste and low energy consumption.



CUSTOMER CARE

Because all our customers are important, our priority is to support them in their projects, build and maintain a long-term partnership to be able to bring the answers adapted to each need. Over 900 distributors around the world trust us.



PROTECTION

We seriously consider the need to protect the operator and provide a secure working environment through our products and services. This is why our filters are free of polluting or toxic products. They can be stored, handled and incinerated or landfilled safely.



MULTICULTURALISM

Aerem is a selfie of multiculturalism and diversity. Our teams are made of men and women of different languages, cultures and origins. It is in this spirit of openness and diversity that we seek to build a partnership with you.



RESPECT & INTEGRITY

We treat others with respect and comply with all internal and external norms and regulations. We strive to always act with transparency and honesty.

Visit our website: www.ucube.swiss

or contact our support service:

For Europe & Africa: customers.eur@aerem.com

For America : customers.ame@aerem.com

For Asia: customers.api@aerem.com

For **quotes** or **orders**, contact one of our sales representatives located in your region.

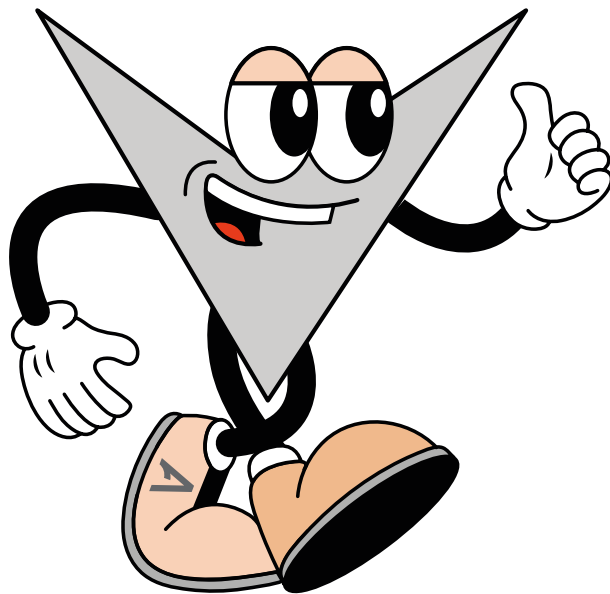

AEREM LOCATIONS WORLDWIDE



AMERICAS



CANADA

5000 Rue Hickmore
Saint-Laurent, QC H4T 1K6
Tel: +1 514-375-7100
Customers.ame@aerem.com



USA

422 2nd Ave NW
Ardmore, OK 73401
Tel: +1 866 263 7323
Customers.ame@aerem.com

EUROPE



SWITZERLAND

Rue du Jeu de L'Arc 15
CH - 1207 Genève
Tel: +41 21 869 93 63
Customers.eur@aerem.com



POLAND

ul. Lubczyńska 6 F
PL - 70-895 Szczecin
Tel: +48 91 884 90 00
Customers.eur@aerem.com

ASIA-PACIFIC



VIETNAM

Workshop No. 54, road No. 1-7 Long
Thanh Industrial Zone
Long Thanh district, Dong Nai province
Tel: +84-251-352-6688
Customers.api@aerem.com



HONG-KONG

20th Floor, Euro Trade Center
21-23 Des Voeux Road Central
Tel: +852 2824 8156
Customers.api@aerem.com

AEREM[®]
TO FILTER & PROTECT

www.aerem.com

Follow us on

